

PRESSURE REGULATORS

Type RP/10



RP/10 Regulators

Type RP/10 Pressure Loaded Regulators

RP/10 regulators are pneumatic-loaded and feature counterbalanced valve.

The RP/10 regulators are normally employed in pressure reducing stations using high pressure gas compressed in cylinders.

They can also be employed with middle pressure gas in ceramic, chemical, and pharmaceutical factories for small furnaces.

The main features are as follows:

- **Counterbalanced Shutter**
- **Built-in Relief Valves**

Operation

The stem S is controlled by the diaphragm unit M on the opposite surfaces of which are balanced in one side the downstream pressure and on the other side the setting static pressure.

The causes that can intervene to modify this state of balance are:

1. increase of the request of gas
2. reduction of the request of gas
3. increase of the inlet pressure
4. reduction of the inlet pressure

An Increase of the request of gas causes a reduction of the downstream pressure in the chamber C1.

The difference of pressure which is thus formed between the chambers C and C1 operating on the diaphragm unit M causes the opening of the shutter O until the balance of the setting and downstream pressure is obtained again.

In the case 2 a reduction of the request of gas causes an increase of the downstream pressure.

The downstream pressure prevailing on the setting pressure causes a rising of the diaphragm unit M and therefore of the shutter O.

The reduction of useful section for the passage which is the consequence of this, reduces the downstream pressure to its initial value.

The cases 3 and 4 are similar to the previous ones because, to the effects of the operation, an Increase or a reduction of the absorption correspond respectively to a reduction or to an increase of the inlet pressure.

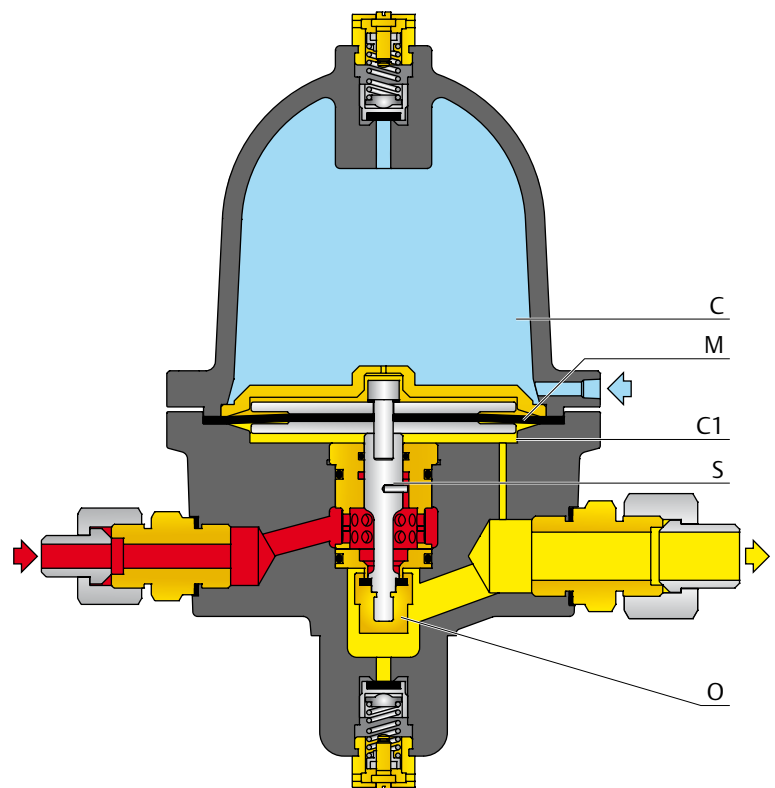

■ Inlet Pressure ■ Downstream Pressure ■ Setting Pressure

Features

Technical Features

Body allowable pressure	PS	: 220 bar
Inlet pressure range	bpu	: 1 to 220 bar
Outlet Set Pressure Ranges	Wd	: 0,5 to 30 mbar

Functional Features

Accuracy class	AC	: up to ±5%
Lock-up pressure class	SG	: up to 10%
Class of lock-up pressure zone	Sz	: up to 10%

Orifice

3/4"

Connections

3/4" x 1" BSP
 Provided with butt weld ends:
 Inlet Ø 17,2 mm - Outlet Ø 26,5 mm

Temperature

Working -10° to 60 °C

Materials

Body	Steel
Covers	Steel
Seat	Stainless Steel
Diaphragm	Fabric Nitrile (NBR) Rubber + PVC
Pad	Nitrile NBR or Fluorocarbon FKM

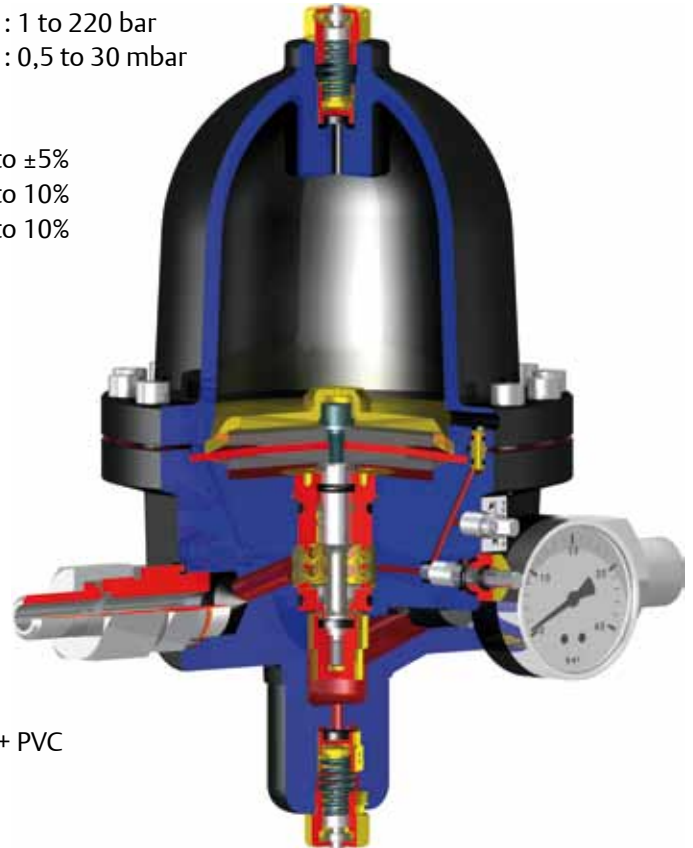

Flow Rates Table (Stm³/h)

pu \ pd	0.5	0.8	1	1.25	1.5	1.8	2	2.5	3	3.5	4	4.5	5	6	7	8	9	10	12.5	15	17.5	20	25	30	
1	60	40																							
1.5	85	75	70	50																					
2	110	100	100	90	75	50																			
3		145	145	140	135	125	120	90																	
4			180	180	180	175	170	160	140	105															
5					220	220	220	205	195	180	155	115													
6							255	255	245	235	220	200	170												
7.5									310	310	300	290	280	265	225	140									
10											400	400	385	365	340	295	220								
12.5												500	500	480	465	440	410	360							
15														580	580	555	540	510	400						
20																765	765	740	700	615	470				
30																			1130	1100	1060	1000	790		
40																					1490	1455	1370	1215	
50																						1855	1810	1735	
75																									
100																									
125	145	180	220	220	255	255	310	330	400	400	500	580	580	650	765	850	950	1130	1250	1490	1855	2000	2000	2000	
150																									
175	Flow rates higher than these values are not possible because this would cause too high gas velocity in the outlet fitting																								
220																									

Verify that the velocity of the gas at the downstream pipeline of the regulator does not exceed 25 m/s using the following formula:

$$V = 345.92 \cdot \frac{Q}{DN^2} \cdot \frac{1 - 0.002 \cdot Pd}{1 + Pd}$$

V = Velocity in m/s
 345.92 = Numerical constant
 Q = Flow rate in Stm³/h
 DN = Pipeline diameter
 Pd = Outlet gauge press. in bar g

Pressures in bar and flow rates in Stm³/h referred to natural gas.

Dimensions (mm) and Weights (kg)

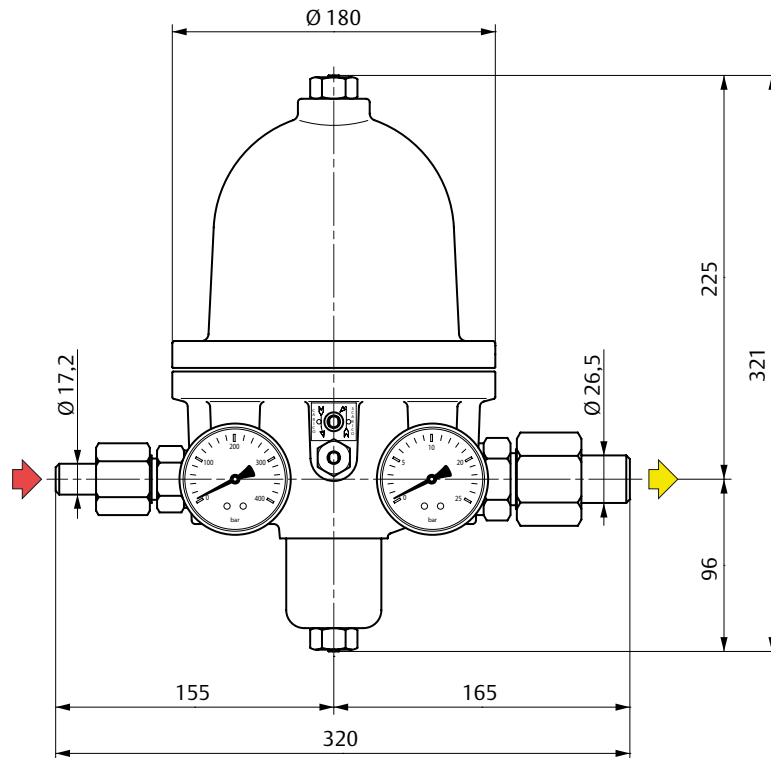

Weight: 17 Kg

Industrial Regulators

**Emerson Process Management
Regulator Technologies, Inc.**

USA - Headquarters
McKinney, Texas 75069-1872 USA
Tel: +1 800 558 5853
Outside US: +1 972 548 3574

Europe
Bologna 40013, Italy
Tel: +39 051 419 0611

Asia-Pacific
Shanghai 201206, China
Tel: +86 21 2892 9000

Middle East and Africa
Dubai, United Arab Emirates
Tel: +971 4811 8100

Natural Gas Technologies

**Emerson Process Management
Regulator Technologies, Inc.**

USA - Headquarters
McKinney, Texas 75069-1872 USA
Tel: +1 800 558 5853
Outside US: +1 972 548 3574

Europe
Bologna 40013, Italy
Tel: +39 051 419 0611
Chartres 28008, France
Tel: +33 2 37 33 47 00

Asia-Pacific
Singapore 128461, Singapore
Tel: +65 6770 8337

LP-Gas Equipment

**Emerson Process Management
Regulator Technologies, Inc.**

USA - Headquarters
McKinney, Texas 75069-1872 USA
Tel: +1 800 558 5853
Outside US: +1 972 548 3574

TESCOM

**Emerson Process Management
Tescom Corporation**

USA - Headquarters
Elk River, Minnesota 55330-2445 USA
Tel: +1 763 241 3238
+1 800 447 1250

Europe
Selmsdorf 23923, Germany
Tel: +49 38823 31 287

Asia-Pacific
Shanghai 201206, China
Tel: +86 21 2892 9499

For further information visit www.emersonprocess.com/regulators

Our Global Product Brands:



The Emerson logo is a trademark and service mark of Emerson Electric Co. All other marks are the property of their prospective owners. Fisher, Tartarini, Francel, Jeon, Tescom and Emerson Process Management and the Emerson Process Management design are marks of the Emerson Process Management group of companies.

The contents of this publication are presented for informational purposes only, and while every effort has been made to ensure their accuracy, they are not to be construed as warranties or guarantees, express or implied, regarding the products or services described herein or their use or applicability. We reserve the right to modify or improve the designs or specifications of such products at any time without notice.

Emerson Process Management does not assume responsibility for the selection, use or maintenance of any product. Responsibility for proper selection, use and maintenance of any Emerson Process Management product remains solely with the purchaser.

